

Installation instructions

i Refer to installation use and maintenance manual for more information.
Available user manual at link <http://www.everelettronica.it/manhw.html>



2 phase bipolar stepper drive technical data:

TITANIO
VECTOR - STEPPER - DRIVES

- AC power supply: 85-265Vac monophase or triphase
- DC logic supply: 24 Vdc (mandatory and isolated)
- Phase current: up to 5,2 Arms (7,3 Apk) with 265VAC MAX or 8 Arms (11,3 Apk) with 120VAC MAX
- Chopper frequency: ultrasonic 40KHz
- Stepless Control Technology (65536 position per turn)
- Protections against: over current, over/under voltage, overheating, short circuit between motor phase-to-phase and phase-to-ground
- Modbus and Canbus communication interfaces
- Incremental Encoder Input: 5V Differential (RS422) or 5V single-ended TTL/CMOS
- Incremental Encoder Output: 5V Differential (RS422)
- Absolute Encoder Input: 5V BiSS-C or SSI interface
- Service SCI interface for programming and real time debugging
- Safe Torque Off (STO) inputs (opto-coupled)
- 16 digital inputs (opto-coupled) SW5A9052L2G1-30 or 4 digital inputs (opto-coupled, SW5A9052L2E1-30)
- 12 digital outputs (opto-coupled) SW5A9052L2G1 or 3 digital outputs (opto-coupled, SW5A9052L2E1-30)
- 2 analog inputs (isolated) SW5A9052L2G1-30 or 1 analog input (isolated) SW5A9052L2E1-30 only
- 2 analog outputs (isolated) SWA9052L2G1-30 only
- Dimensions: 196.6 x 136.6 x 47 mm (without connectors)
- Protection degree: IP20
- Pollution degree 2
- Overvoltage Category III
- Short Circuit Current: 5 KA
- Protection Class: Class I Equipment
- Working temperature 5°C + 50°C ; Storage temperature -25°C + 55°C
- Humidity: 5% + 85% not condensing

CANopen
RS485

Modbus



Mechanical data

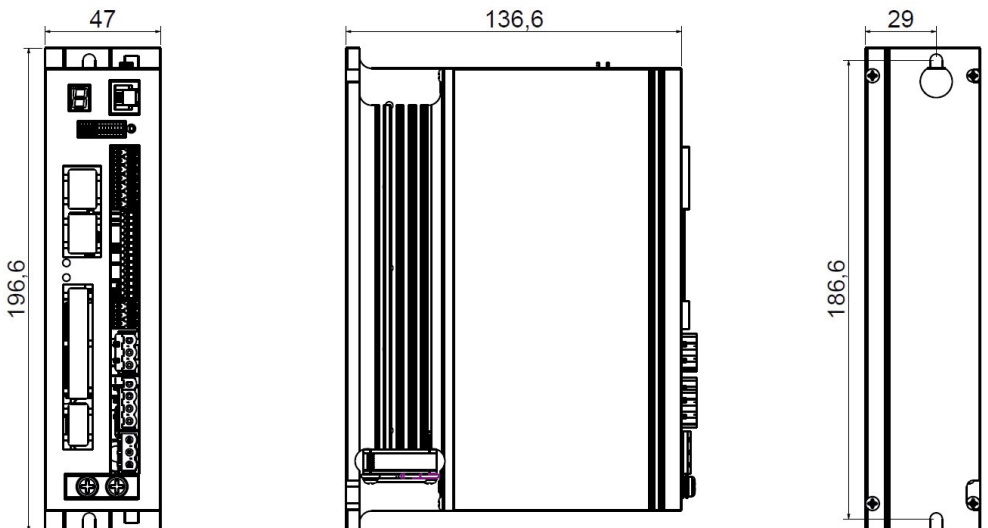

Ordering codes characteristics

System code	Digital inputs	Digital outputs	Analog inputs	Analog outputs
SW5A9052L221-30	4	3	0	0
SW5A9052L2E1-30	4	3	1	0
SW5A9052L2G1-30	16	12	2	2

System connectors

Connectors:

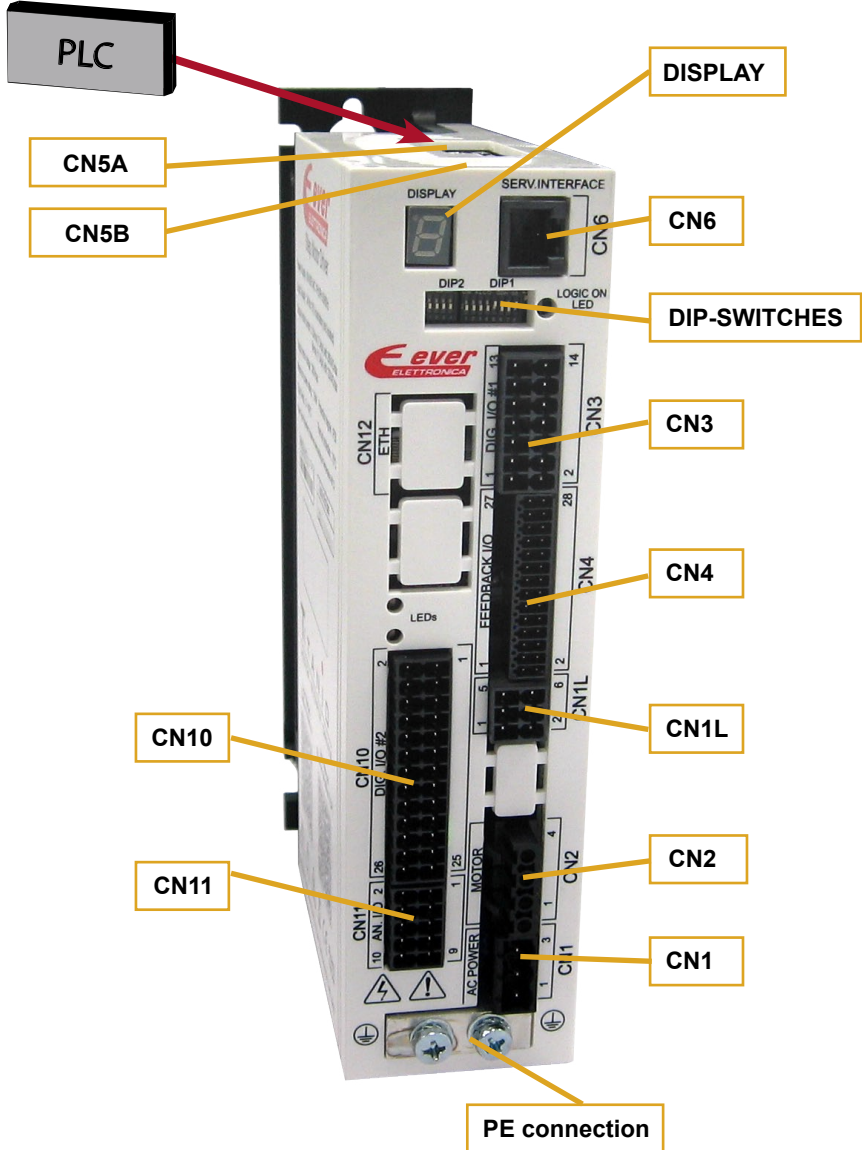

System connections

CN1: Power supply

3 positions, pitch 5.08mm double row, PCB header connector

CN1.1	ACin	PWR_IN	AC power supply input
CN1.2	ACin	PWR_IN	AC power supply input
CN1.3	ACin	PWR_IN	AC power supply input

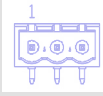

CN2: Motor connection

4 positions, pitch 5.08mm single row, PCB socket connector

CN2.1	A/	PWR_OUT	Motor output phase A/
CN2.2	A	PWR_OUT	Motor output phase A
CN2.3	B	PWR_OUT	Motor output phase B
CN2.4	B/	PWR_OUT	Motor output phase B/

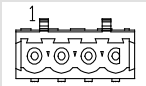

CN1L: 24Vdc Logic Supply and STO inputs

6 positions, pitch 3.5mm double row, PCB header connector

CN1L.1	VLOG -	PWR_IN	Negative DC logic supply input
CN1L.2	VLOG +	PWR_IN	Positive DC logic supply input
CN1L.3	STO1 -	PWR_IN	STO1 input negative side
CN1L.4	STO1 +	PWR_IN	STO1 input positive side
CN1L.5	STO2 -	PWR_IN	STO2 input negative side
CN1L.6	STO2 +	PWR_IN	STO2 input positive side

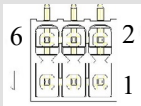

LOGIC 24 Vdc MANDATORY and ISOLATED

CN6: Service SCI Interface

RJ11, 6P4C, PCB header connector

CN6.1	TX/RX	Transmit / Receive Line
CN6.2	DE/RE	Drive Enable Negated /Receive Enable
CN6.3	+5V	+5V power out
CN6.4	GND	GND power out



This connection is only possible with hardware and software provided by Ever Elettronica.

CN3: Digital Inputs / Outputs #1

14 positions, pitch 3.5mm double row, PCB header connector

CN3.1	VSS#1	PWR_IN	Negative supply for digital outputs B0 on CN3
CN3.2	V-OUT0	PWR_IN	24 Vdc supply for digital outputs B0 on CN3
CN3.3	B0_OUT0	DIG_OUT	PNP digital output B0_OUT0
CN3.4	B0_OUT1	DIG_OUT	PNP digital output B0_OUT1
CN3.5	B0_OUT2	DIG_OUT	PNP digital output B0_OUT2
CN3.6	N.C.	---	Not connected
CN3.7	-B0_IN0	DIG_IN	Digital input B0_IN0 negative side
CN3.8	+B0_IN0	DIG_IN	Digital input B0_IN0 positive side
CN3.9	-B0_IN1	DIG_IN	Digital input B0_IN1 negative side
CN3.10	+B0_IN1	DIG_IN	Digital input B0_IN1 positive side
CN3.11	-B0_IN2	DIG_IN	Digital input B0_IN2 negative side
CN3.12	+B0_IN2	DIG_IN	Digital input B0_IN2 positive side
CN3.13	-B0_IN3	DIG_IN	Digital input B0_IN3 negative side
CN3.14	+B0_IN3	DIG_IN	Digital input B0_IN3 positive side

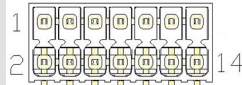

CN4: Feedback connection

28 position, pitch 2,54mm double row, PCB header connector

CN4.1	Shield	/	Cable shield connection for feedback interface
CN4.2	Shield	/	Cable shield connection for feedback interface
CN4.3	N.C.	---	Not connected
CN4.4	N.C.	---	Not connected
CN4.5	DATA-	DIG_IN	Absolute encoder data input negative
CN4.6	DATA+	DIG_IN	Absolute encoder data input positive
CN4.7	CLK-	DIG_OUT	Absolute encoder clock output negative
CN4.8	CLK+	DIG_OUT	Absolute encoder clock output positive
CN4.9	Reserved	---	Reserved pin
CN4.10	Reserved	---	Reserved pin
CN4.11	Reserved	---	Reserved pin
CN4.12	N.C.	---	Not connected
CN4.13	ENCZ-	DIG_IN	Encoder Zero differential input negative
CN4.14	ENCZ+	DIG_IN	Encoder Zero differential input positive
CN4.15	ENCB-	DIG_IN	Encoder Phase B differential input negative
CN4.16	ENCB+	DIG_IN	Encoder Phase B differential input positive
CN4.17	ENCA-	DIG_IN	Encoder Phase A differential input negative
CN4.18	ENCA+	DIG_IN	Encoder Phase A differential input positive
CN4.19	0VE	PWR_OUT	Negative side of supply
CN4.20	+5E	PWR_OUT	+5Vdc power supply output
CN4.21	OUT_ENCZ-	DIG_OUT	Encoder Zero differential output negative
CN4.22	OUT_ENCZ+	DIG_OUT	Encoder Zero differential output positive
CN4.23	OUT_ENCB-	DIG_OUT	Encoder Phase B differential output negative
CN4.24	OUT_ENCB+	DIG_OUT	Encoder Phase B differential output positive
CN4.25	OUT_ENCA-	DIG_OUT	Encoder Phase A differential output negative
CN4.26	OUT_ENCA+	DIG_OUT	Encoder Phase A differential output positive
CN4.27	0VE	PWR_OUT	Reference ground for feedback interface
CN4.28	0VE	PWR_OUT	Reference ground for feedback interface



System connections

CN10: Digital I/O #2

26 positions, pitch 3.5mm double row, PCB header connector

CN10.1	+24Vdc	PWR_IN	24 Vdc supply for digital outputs B1 on CN10
CN10.2	VSS#2	PWR_IN	Negative reference for digital inputs and outputs on CN10
CN10.3	VSS#2	PWR_IN	Negative reference for digital inputs and outputs on CN10
CN10.4	B0_OUT3	DIG_OUT	PNP digital output B0_OUT3
CN10.5	B1_OUT0	DIG_OUT	Digital output B1_OUT0 (PNP)
CN10.6	B1_OUT1	DIG_OUT	Digital output B1_OUT1 (PNP)
CN10.7	B1_OUT2	DIG_OUT	Digital output B1_OUT2 (PNP)
CN10.8	B1_OUT3	DIG_OUT	Digital output B1_OUT3 (PNP)
CN10.9	B1_OUT4	DIG_OUT	Digital output B1_OUT4 (PNP)
CN10.10	B1_OUT5	DIG_OUT	Digital output B1_OUT5 (PNP)
CN10.11	B1_OUT6	DIG_OUT	Digital output B1_OUT6 (PNP)
CN10.12	B1_OUT7	DIG_OUT	Digital output B1_OUT7 (PNP)
CN10.13	B0_IN8	DIG_IN	Digital input B0_IN8
CN10.14	B0_IN9	DIG_IN	Digital input B0_IN9
CN10.15	B0_IN10	DIG_IN	Digital input B0_IN10
CN10.16	B0_IN11	DIG_IN	Digital input B0_IN11
CN10.17	B0_COM_IN	PWR_IN	Reference common inputs B0 on CN10
CN10.18	B1_IN0	DIG_IN	Digital input B1_IN0
CN10.19	B1_IN1	DIG_IN	Digital input B1_IN1
CN10.20	B1_IN2	DIG_IN	Digital input B1_IN2
CN10.21	B1_IN3	DIG_IN	Digital input B1_IN3
CN10.22	B1_IN4	DIG_IN	Digital input B1_IN4
CN10.23	B1_IN5	DIG_IN	Digital input B1_IN5
CN10.24	B1_IN6	DIG_IN	Digital input B1_IN6
CN10.25	B1_IN7	DIG_IN	Digital input B1_IN7
CN10.26	B1_COM_IN	PWR_IN	Reference common inputs B1 on CN10

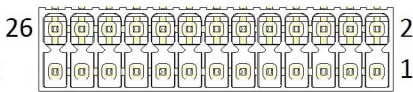

CN11: Analog I/O

10 positions, pitch 3.5mm double row, PCB header connector

CN11.1	AVSS	PWR_OUT	Negative output reference for analog outputs
CN11.2	OUT_AN0	AN_OUT	Analog output 0 positive side
CN11.3	AVSS	PWR_OUT	Negative output reference for analog outputs
CN11.4	OUT_AN1	AN_OUT	Analog output 1 positive side
CN11.5	-IN_AN0	AN_IN	Analog input 0 negative side
CN11.6	+IN_AN0	AN_IN	Analog input 0 positive side
CN11.7	-IN_AN1	AN_IN	Analog input 1 negative side
CN11.8	+IN_AN1	AN_IN	Analog input 1 positive side
CN11.9	AGND	PWR_OUT	Negative output reference for potentiometer
CN11.10	VPOT	PWR_OUT	Voltage supply output for potentiometer

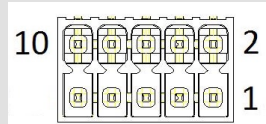

CN5A and CN5B: CANbus & Modbus Interfaces

RJ45, 8 positions shielded, PCB header connector

CN5.1	CAN_H	Digital I/O	Bus Line Dominant HIGH (CANbus)
CN5.2	CAN_L	Digital I/O	Bus Line Dominant LOW (CANbus)
CN5.3	CAN_GND	PWR_OUT	Signal Ground for CANbus
CN5.4	Data +	Digital I/O	Positive RS485 signal (Modbus)
CN5.5	Data -	Digital I/O	Negative RS485 signal (Modbus)
CN5.6	Cto Cto between pins 6 of CN5A and CN5B	---	IN-OUT for CAN_SHLD (CANbus)
CN5.7	0V_A	PWR_OUT	Signal Ground for Modbus
CN5.8	Cto Cto between pins 8 of CN5A and CN5B	---	IN-OUT for CAN_V+ (CANbus)



Jumper - Termination Resistor

Position 1	120ohm resistor INSERTED on CANbus network
Position 2	120ohm resistor INSERTED on Modbus network

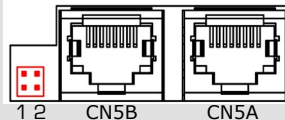

Service SCI connection



This connection is only possible with hardware and software provided by Ever.
Kit code: SW5_SERV00-SL or SW5-SERV00-EE.

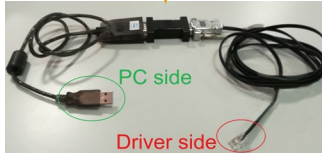

Dip-Switched Settings

DIP2



DIP1



NOTE: the device reads the Dip-Switches only during the Power up.
If it's necessary a setting change, shut down the system, change the settings and start up the system again to make the changes operating.

Dip-switch allocation

DIP2				DIP1							
U1	U0	ID6	ID5	ID4	ID3	ID2	ID1	ID0	BD2	BD1	BD0
1			4	1							8

Drive's Baud Rate selection

BD2	BD1	BD0	Modbus	CANopen
OFF	OFF	OFF	115200	1 M
OFF	OFF	ON	57600 (default)	500 K (default)
OFF	ON	OFF	38400	250 K
OFF	ON	ON	19200	125 K
ON	OFF	OFF	9600	100 K
ON	OFF	ON	4800	50 K
ON	ON	OFF	2400	50 K
ON	ON	ON	1200	50 K

Drive's Baud Rate selection

ID6	ID5	ID4	ID3	ID2	ID1	ID0	Node ID #
OFF	OFF	OFF	OFF	OFF	OFF	OFF	Not allowed
OFF	OFF	OFF	OFF	OFF	OFF	ON	1 (default)
OFF	OFF	OFF	OFF	OFF	ON	OFF	2
OFF	OFF	OFF	OFF	OFF	ON	ON	3
OFF	OFF	OFF	OFF	ON	OFF	OFF	4
OFF	OFF	OFF	OFF	ON	OFF	ON	5
OFF	OFF	OFF	OFF	ON	ON	OFF	6
OFF	OFF	OFF	OFF	ON	ON	ON	7
OFF	OFF	OFF	ON	OFF	OFF	OFF	8
OFF	OFF	OFF	ON	OFF	OFF	ON	9
OFF	OFF	OFF	ON	ON	ON	OFF	10
OFF	OFF	OFF	ON	ON	ON	ON	11
OFF	OFF	OFF	ON	ON	OFF	OFF	12
OFF	OFF	OFF	ON	ON	OFF	ON	13
OFF	OFF	OFF	ON	ON	ON	OFF	14
OFF	OFF	OFF	ON	ON	ON	ON	15
OFF	OFF	ON	OFF	OFF	OFF	OFF	16
OFF	OFF	ON	OFF	OFF	OFF	ON	17
OFF	OFF	ON	OFF	OFF	ON	OFF	18
OFF	OFF	ON	OFF	ON	ON	ON	19
OFF	OFF	ON	OFF	ON	OFF	OFF	20
OFF	OFF	ON	OFF	ON	OFF	ON	21
OFF	OFF	ON	OFF	ON	ON	OFF	22
OFF	OFF	ON	OFF	ON	ON	ON	23
OFF	OFF	ON	ON	OFF	OFF	OFF	24
XX	XX	XX	XX	XX	XX	XX
ON	ON	ON	ON	ON	ON	ON	127

Display Status

Operational statuses and their signals

	Missing Operating System: no software application stored on drive
	Firmware update: Updating of new software in progress.
	Initialization: the drive executes the start-up procedure (a few seconds after the start-up procedure has begun).
	Correct functioning
+	Voltage of the DC bus near to the limit value (minimum or maximum)
+	Drive temperature is near to the maximum value
+	Warning: EEPROM near Write Overrun
+	Warning: EEPROM near End of Life
flashing	Enable OFF, current zero
flashing	$I_{nominal}$ not computed
+	Error: expired eePLC software trial
+	Security intervention of watchdog
+	Internal Software Error
+	Missing calibration values
+	Management EEPROM
+	EEPROM fail
+	Error: eePLC application error
+	Error: EEPROM Write Overrun
+	Error: Feature Unavailable (the application tried to use a feature that is not available in the current drive configuration)
+	Open motor phases
+	Over/under voltage;
+	Over current on the motor output;
+	Over temperature of the drive;
+	Missing Torque Enable ("Missing Safe Torque Off")
+	Drive over power protection and/or current regulation out of range
+	eePLC User Protection (generated by setting bit #0 of eePLC_User_Settings)
+	Motor feedback error

Power & Logic Supply connections

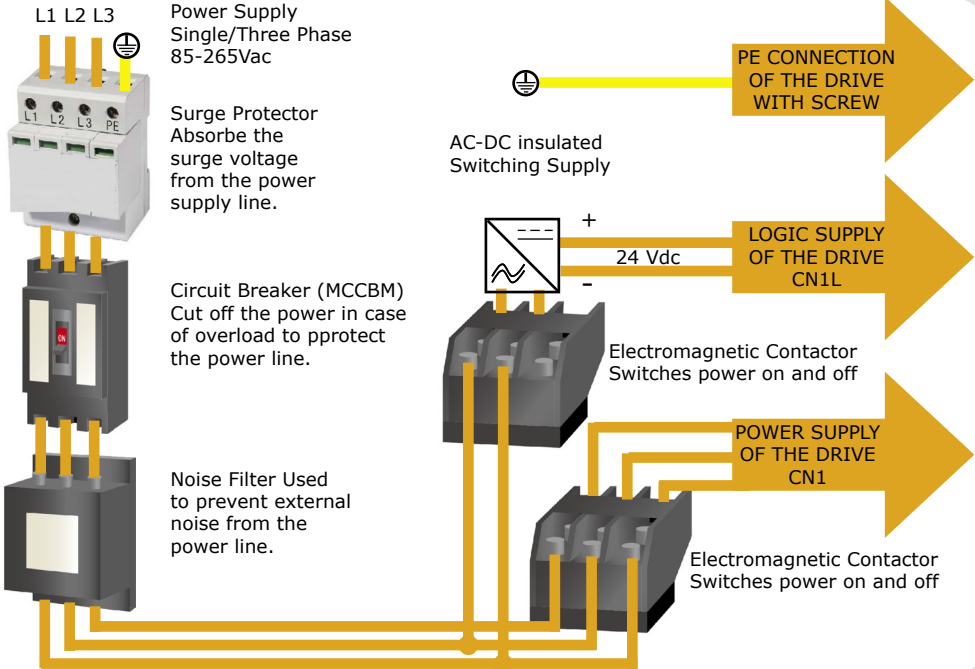

Absolute Encoder input connection

(Maximum supply current 100mA)

Differential 5Vdc digital inputs that meet the RS422 standard.

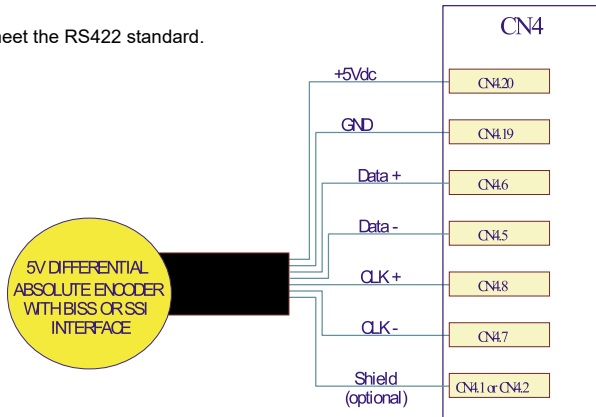

Incremental Encoder input connection

(Maximum supply current 100mA)

Differential 5Vdc digital inputs that meet the RS422 standard.

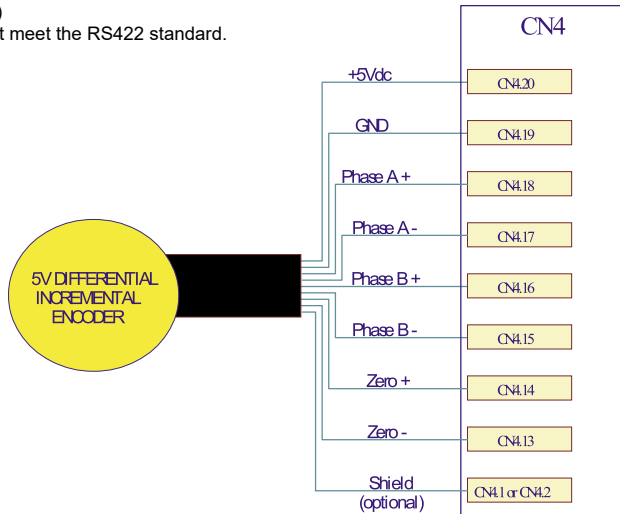

Single-Ended 5Vdc TTL/CMOS digital inputs

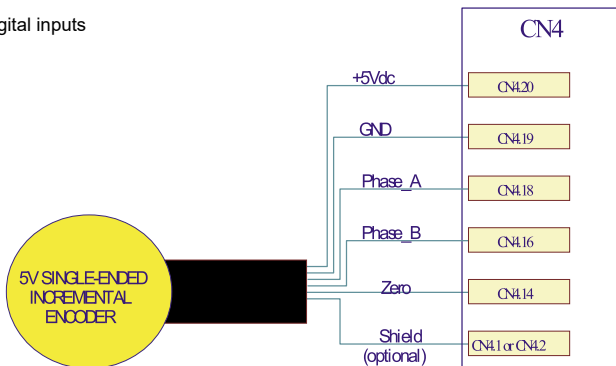

Incremental Encoder output connection

Outputs reports the used interface for encoder input : Differential or Single-Ended.
Differential 5V digital outputs that meets RS422 standard.

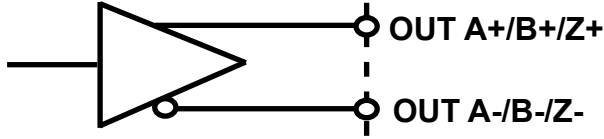

Safe Torque Off inputs (STO)

2 terminals, 24V compatible (optoisolated)

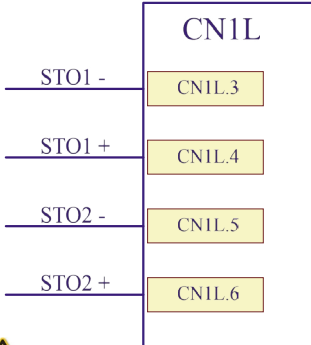

STO1	STO2	Drive Status	Motor Status
+24Vdc	+24Vdc	Enable	SW controlled
+24Vdc	Not connected	Disable	Stop for inertia
Not connected	+24Vdc	Disable	Stop for inertia
Not connected	Not connected	Disable	Stop for inertia



STO inputs are optoisolated, shall not be used the same 24 Vdc of logic supply for their connection.

Safety specifications

Safety function	STO	Safe Torque Off
Category	4	In according with EN ISO 13849-1
Performance Level	PLe	In according with EN ISO 13849-1
Safety Integrity Level	SIL3	In according with EN ISO 13849-1 table 3
DC _{avg} [%]	99	Average Diagnostic Coverage
PFH _D [1/h]	6.44 x 10 ⁻⁹	Probability of dangerous failure per hour
T Service Life [Years]	20	In accordance with EN ISO 13849-1
Type test	The STO function has been certified by an independent testing body.	



Refer to the "Safety Manual_STO on SW5-AW5 Series" for more details of the Safe Torque Off function characteristics.

Principle of operation:

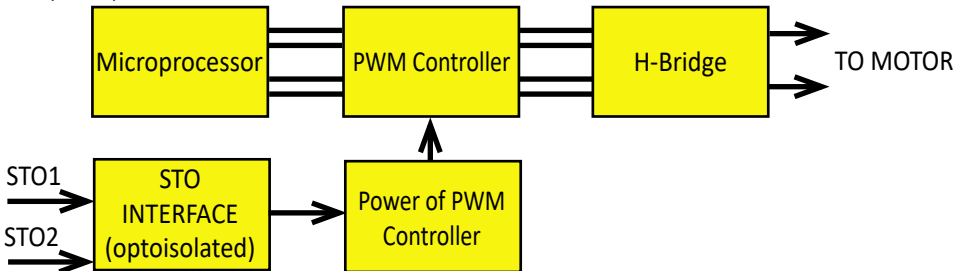

The drive has a safety feature that is designed to provide the Safe Torque Off (STO) function as defined in IEC 61800-5-2. Two input signals are provided which, when not connected, prevent the upper and lower devices in the PWM outputs from being operated by the digital control core. This provides a positive OFF capability that cannot be overridden by the control firmware, or associated hardware components. When both STO signals are activated (current is flowing in the input diodes of the optocouplers), the control core will be able to control the on/off state of the PWM outputs.



If not using the STO feature, both signals must be connected to a 24Vdc supply in order enabled the drive.



If a drive in operation mode is disabled by STO signal, it immediately finish to produce torque but the motor continues to run by inertia until it can stop.

Digital inputs connection

Digital input connection (B0_IN0 to B0_IN3)

i Differential PNP, NPN and Line Driver type.

3.3 - 24V INPUT

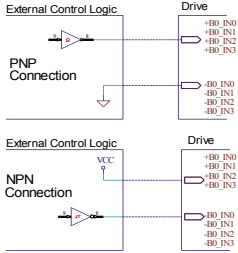

2 - 24V INPUT

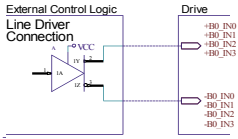

B0_IN0 and B0_IN1

Characteristics	MIN.	MAX.	Unit
Supply voltage	2 ⁽¹⁾	24	Vdc
Inputs frequency	--	10	kHz
Threshold switching voltage	1.61 ⁽¹⁾	--	Vdc
Current at 2 Vdc	--	2.53	mA
Current at 3.3 Vdc	--	5.84	mA
Current at 5 Vdc	--	6.28	mA
Current at 24 Vdc	--	8.75	mA

B0_IN2 and B0_IN3

Characteristics	MIN.	MAX.	Unit
Supply voltage	2 ⁽¹⁾	24	Vdc
Inputs frequency	--	500	kHz
Threshold switching voltage	1.61 ⁽¹⁾	--	Vdc
Current at 2 Vdc	--	2.53	mA
Current at 3.3 Vdc	--	5.84	mA
Current at 5 Vdc	--	6.28	mA
Current at 24 Vdc	--	8.75	mA

⁽¹⁾ N.B.: it's recommended to use 2 Vdc digital inputs only in differential Line-Driver configuration to have more noise immunity.

Digital inputs connection (B0_IN8 to B0_IN11)

i Single-Ended PNP, NPN, Push-Pull

5 - 24V INPUT

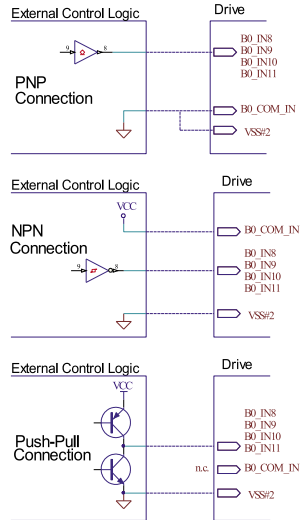

B0_IN8 to B0_IN11

Characteristics	MIN.	MAX.	Unit
Supply voltage	5	24	Vdc
Inputs frequency	--	100	kHz
Threshold switching voltage	2	--	Vdc
Current at 5 Vdc	--	2	mA
Current at 24 Vdc	--	12	mA

N.B.: All these inputs must be connected with the same configuration (PNP, NPN or Push-Pull).

Digital inputs connection (B1_IN0 to B1_IN7)

i Single-Ended PNP, NPN, Push-Pull

Characteristics	MIN.	MAX.	Unit
Supply voltage	5	24	Vdc
Inputs frequency	--	250	Hz
Threshold switching voltage	2.5	--	Vdc
Current at 5 Vdc	--	2	mA
Current at 24 Vdc	--	12	mA

N.B.: All these inputs must be connected with the same configuration (PNP, NPN or Push-Pull).

5 - 24V INPUT

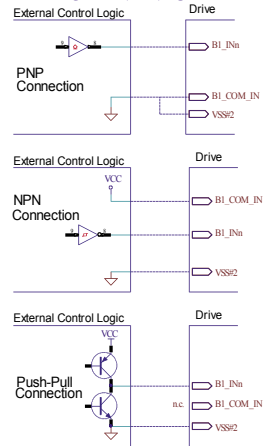

Digital outputs connection

Digital outputs connection (B0_OUT0 and B0_OUT1)

i PNP with $V_{OUTmax}=24Vdc$, $I_{OUTmax}=100mA$, $F_{max} = 500KHz$

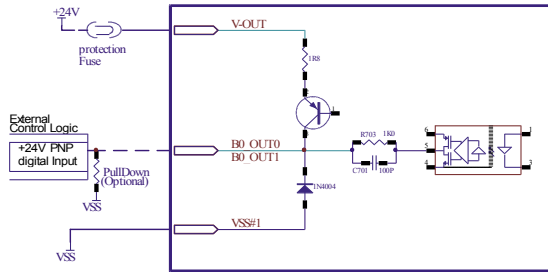

Digital outputs connection (B0_OUT2)

i PNP with $V_{OUTmax}=24Vdc$, $I_{OUTmax}=1.3A$, $F_{max} = 1KHz$

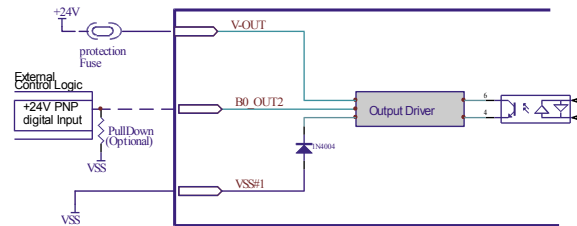

Digital outputs connection (B0_OUT3)

i PNP with $V_{OUTmax}=24Vdc$, $I_{OUTmax}=500mA$, $F_{max} = 1KHz$

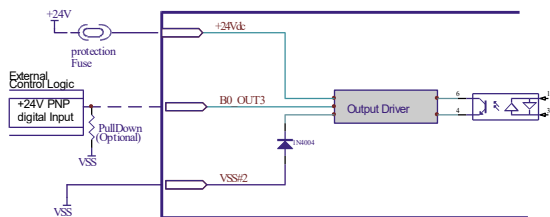

Digital outputs connection (B1_OUT0 and B1_OUT7)

i PNP with $V_{OUTmax} = 24Vdc$, $I_{OUTmax} = 100mA$, $F_{max} = 250Hz$

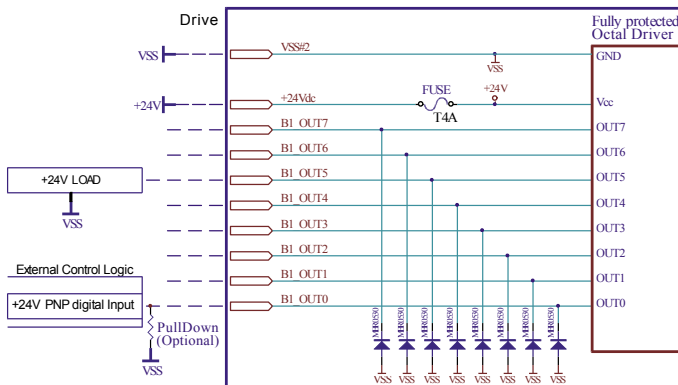

Analog inputs connection

i Isolated configurable analog inputs. The resolution of the analog inputs depends from the type of the connection which could be defined by software: differential or potentiometer.

Differential connection

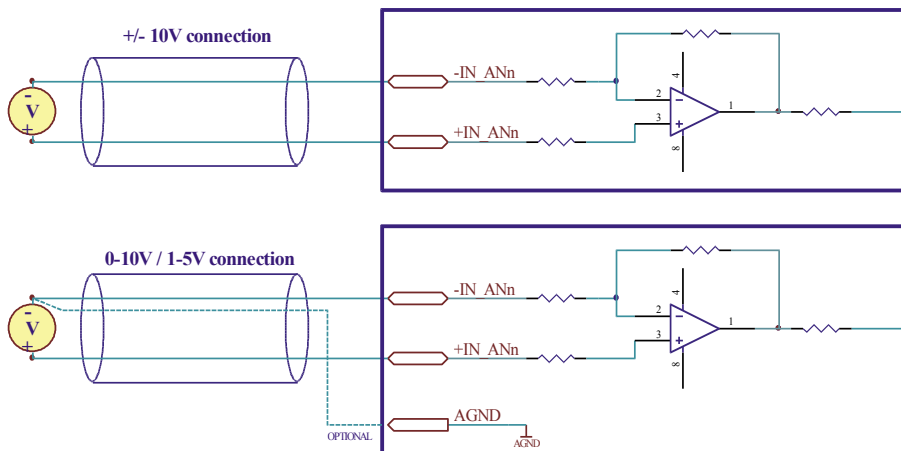

Potentiometer connection

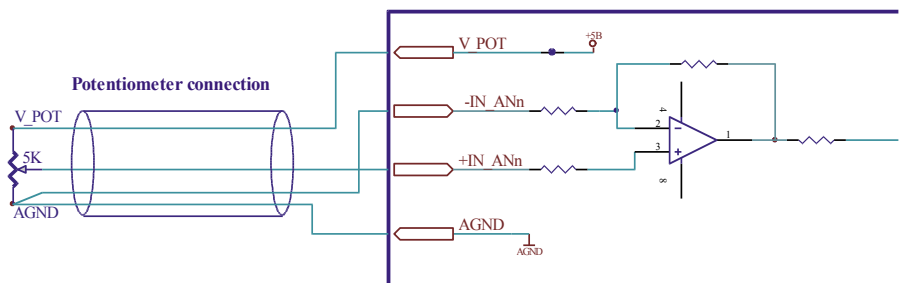

Analog outputs connection

i 0-10V isolated analog outputs.

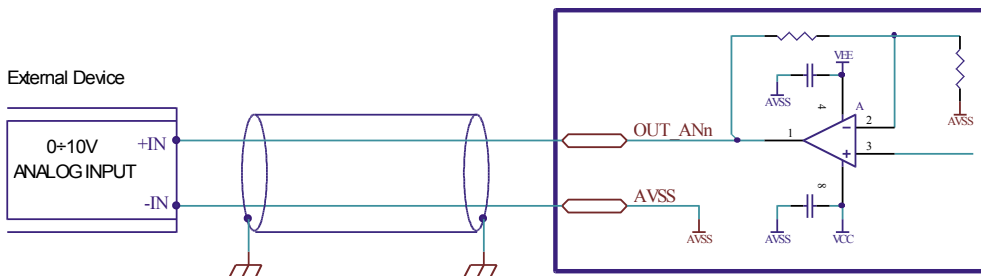

UL regulation requirements

In order to comply with cURus certification according to the UL 61800-5-1 standard, the following requirements must be met:



File number E363861

Eating system

IT or TN (not corner earthed).

The drive shall be considered only for use in system voltage where the maximum voltage between the ungrounded conductors and ground does not exceed 150 V

Maximum length of the cables

Cable	Length
AC Power Supply	No limitation
24 Vdc Power supply & STO	No limitation
Motor	< 30m
Feedback	< 30m
Input & Output	< 30m
Fieldbus	< 30m

Motor cable must be shielded

Fuses on AC Power Supply

In the final installation use only Cooper Bussmann FWX-20 A14F fast fuses on AC bus with 20Arms of current, 250Vac voltage and interrupt rating 200KA or any equivalent UL Listed or UL Recognized External Semiconductor Fuses, on condition that these fuses have the same ratings of the above fuse in particular with "Peak-let-through-current I_p " and "Clearing I_2t "

Discharge time of the capacitors on the AC power supply



CAUTION - Risk of Electric Shock

Time required for the discharge of the capacitors after the removal of the AC power supply: 4 minutes.

Dissipation



To reach the maximum performances with 100% of duty cycle, the drive shall be fixed on the side to an aluminum heat-sink with dimension of 330x305 mm with 5 mm in thickness and with an external R/C Fans, Electric (GPWV2/8) with an Air flow rate minimum of 50 m3/h positioned on the bottom side of the device like indicated in the picture above. Use with a smaller aluminum heat-sink and a lower Fan Air Flow shall be taken into consideration in the end-use application.

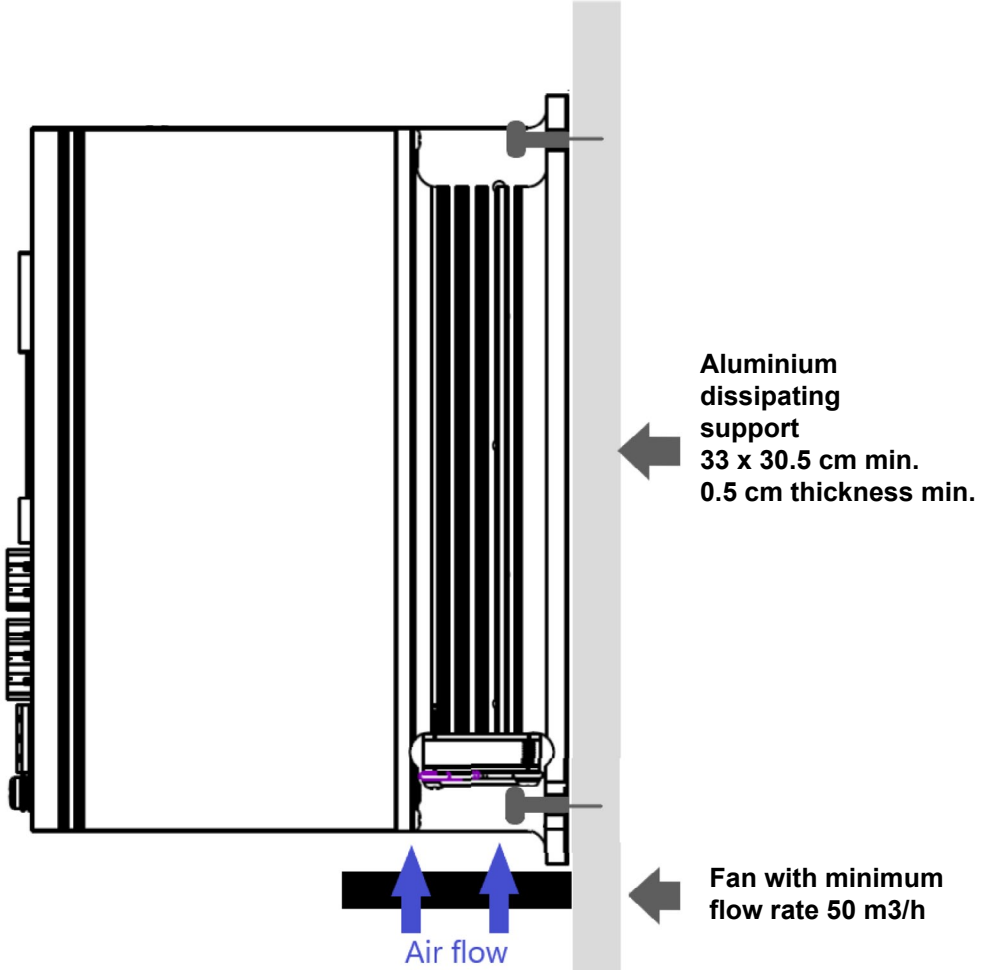

Mating connectors

Connector	Description
CN1	Phoenix 1762208 (Green) or 1759509 (Black)
CN1L	Phoenix 1790111 (Green) or 1708329 (Black)
CN2	Phoenix 1786190 (Green) or 1731196 (Black)
CN3	Phoenix 1790153 (Green) or DFMC 1.5/ 7-ST-3.5 BK (Black)
CN4	Phoenix 1844691
CN5A/CN5B	RJ45, 8 positions for Ethernet standard cables (CAT5 or higher)
CN10	Phoenix 1790218 (Green) or DFMC 1.5/13-ST-3.5 BK (Black)
CN11	Phoenix 1790237 (Green) or 1812542 (Black)

Section of the cables

Function	Cable	
	Minimum	Maximum
Power supply and PE	0.5 mm ² (AWG20)	2.5 mm ² (AWG12)
Motor output	0.5 mm ² (AWG20)	2.5 mm ² (AWG12)
Feedback	0.12 mm ² (AWG26)	0.5 mm ² (AWG20)
Logic supply and Inputs / Outputs	0.5 mm ² (AWG20)	1.3 mm ² (AWG16)
Communication interfaces	Minimum 0.25 mm ² (AWG23) CANbus CiA-CANopen	

Verify the installation

- Check all connection: power supply, logic supply, STO inputs and inputs/outputs.
- Make sure all settings right for the application.
- Make sure the power supply is suitable for the drive.
- If possible, remove the load from the motor shaft to avoid that wrong movements cause damage.
- Enable the current to the motor and verify the applied torque.
- Enable a movement of some steps and verify if the rotation direction is the desired one.
- Disconnect the power supply, connect the load on the motor and check the full functionality.

Analysis of malfunctions



When one of the following situations occur, the drive doesn't function correctly and it is reported an error.

DEFECT	CAUSE	ACTION
The external fuse to the drive burns	May be due to a wrong connection of the power supply.	Adjust the connection and recover the fuse. Use a fuse suitable for the application.
Over temperature protection.	May be due to a duty cycle	Increase the air flux and if it is possible chose a motor with higher torque at same current value.
Over current protection.	May be due to a short circuit on the motor power stage.	Shut down the power supply and check if the motor is damaged
Noisy motor movement with vibrations.	May be caused due to a state of resonance.	Increase the resolution of the step angle and/or change the motor velocity to avoid resonance area
The motor produce torque but doesn't rotate	May be caused due to a wrong connection of the I/O's.	Check the connection of the I/O's

EVER Elettronica
 Via del Commercio, 2/4 - 9/11
 Loc. San Grato Z. I
 26900 - L O D I - Italy
 Phone +39 0371 412318 - Fax +39 0371 412367
 email: infoever@everelettronica.it
 web: www.everelettronica.it

